

PCR

Model-based predictive control improves the stability and reduces the batch duration of a chemical reactor at BASF – Antwerp in Belgium

The 50 m³ reactor requires a tight temperature control because the injected reactants produce a strong exothermic reaction during the batch which lasts about 3 hours. If the T1 reactor temperature gets higher than a limit, the reactants injection is interrupted until the temperature moves back.

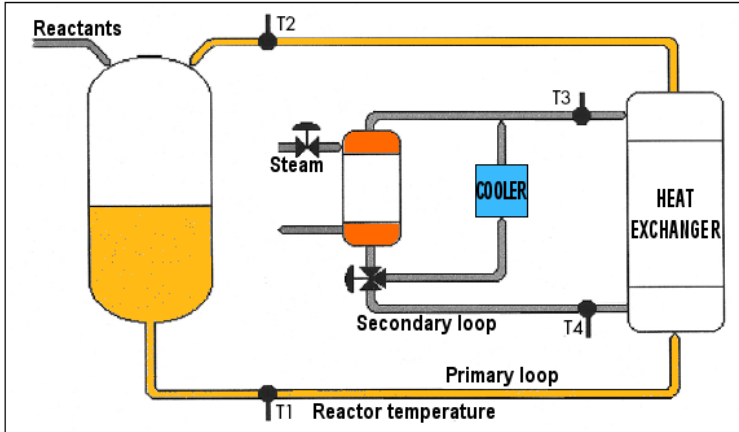

The product circulates in the primary loop which exchanges calories in the heat exchanger. The secondary loop is controlled at T3 temperature by acting on a 3-way valve, heating or cooling the fluid to this heat exchanger.

The reactor is fed continuously during the batch. Therefore, its level increases with time: that modifies the dynamics effect of T2 variations on the reactor temperature T1. This is a first reason which makes difficult the control by regular PID controllers.

A second reason is the important dynamics differences between the heating and cooling devices: a classical split-range control is always mismatched since it does not fit any of these dynamics. A set of PCR modules, including a specific split-range module SR1, is designed to manage correctly such a situation.

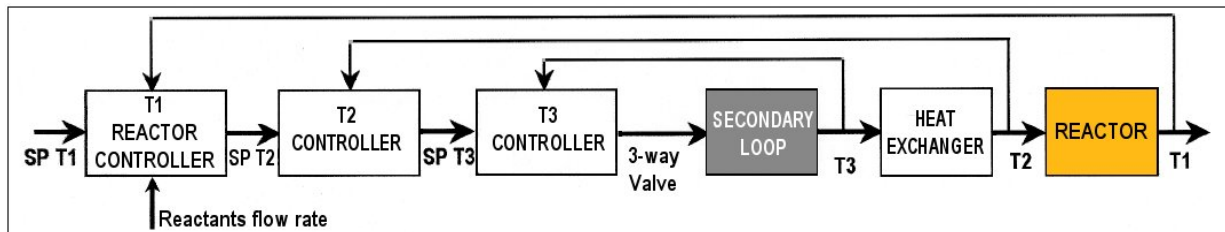

The control of the temperature is performed by a cascade of 3 PCR controllers, handling successively T3, T2 and T1. The T1 controller takes the reactant flow rate into account as a feed forward variable with the corresponding FF1 PCR module. The parameters of the model used by this T1 controller are adapted in real time as pre-programmed functions: the delay and time constant depend on the varying level of product in the tank.

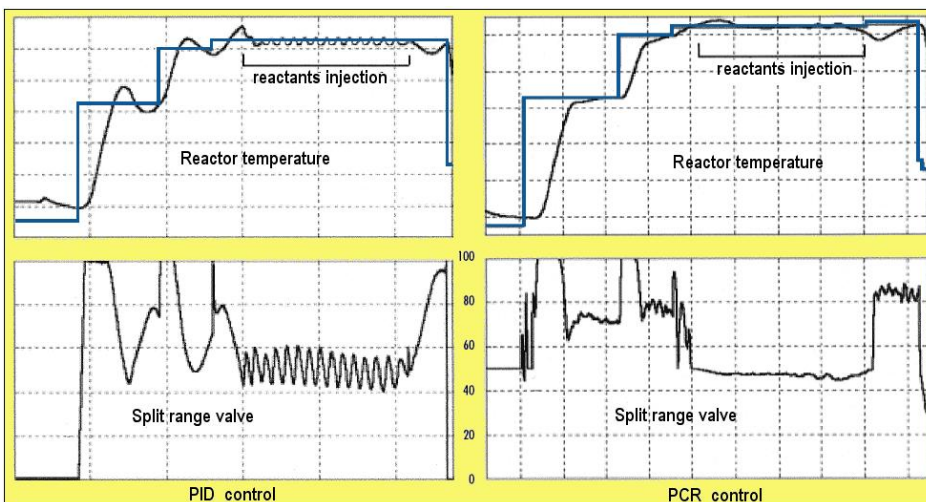

The comparison shows the improvement obtained by PCR:

- the set point steps are respected without overshoots
- the valve oscillations are erased during the injection of reactants
- the reactor temperature never passes its high limit.

All these items explain the 100% service factor.