

# FUEL CELL SIMULATION PLATFORM

Sherpa Engineering has developed expertise in Fuel Cell activities for automotive and other industries for over 20 years. Through multiple R&D projects with European OEMs, we have developed state-of-the-art multi-disciplinary modeling and controls system design tools.

## FUEL CELL ACTIVITIES

Control system design and Fuel Cell system diagnosis are essential engineering tasks. We have an active role in these tasks when working with our customer since we take in charge system design process from system specifications until validation on test bench or prototype vehicles.

## Our Technical Fields

### Modeling & Simulation

- Fuel Cell Stack: Dynamic model
- Component (compressor, pump, humidifier....)
- Global model: Fuel Cell / Cooling / Electrical / Mobility System
- Architecture evaluation and Sizing

### Integration and Validation

- Fast prototyping – Model Based Calibration
- Test specification and requirement validation

### Control System Design

- Control and default detection of the Fuel Cell power module
- Thermal management
- Power control strategy for Fuel Cell Mobility

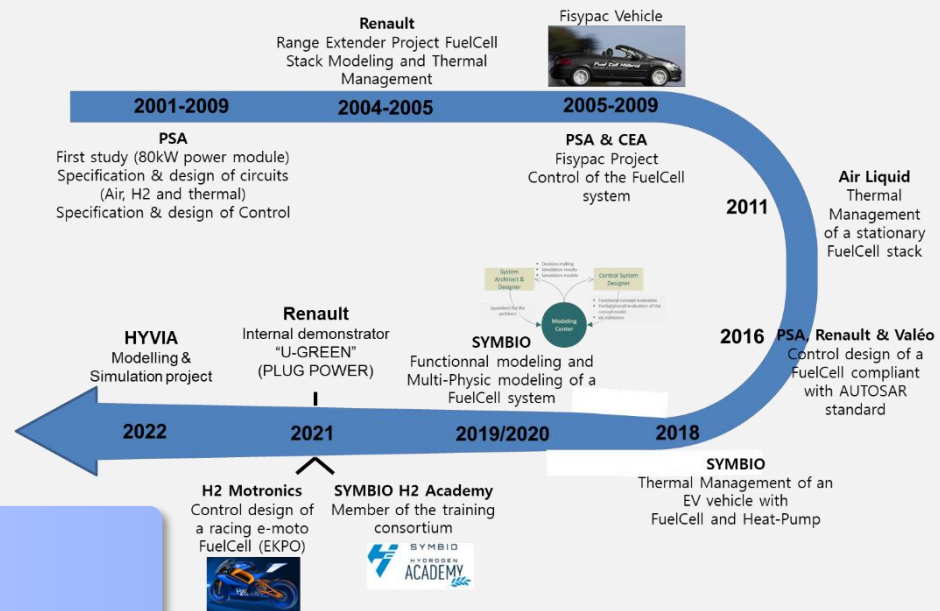

## Description of the Simulation Platform

Fuel Cell Platform extends MATLAB - Simulink modeling and simulation.

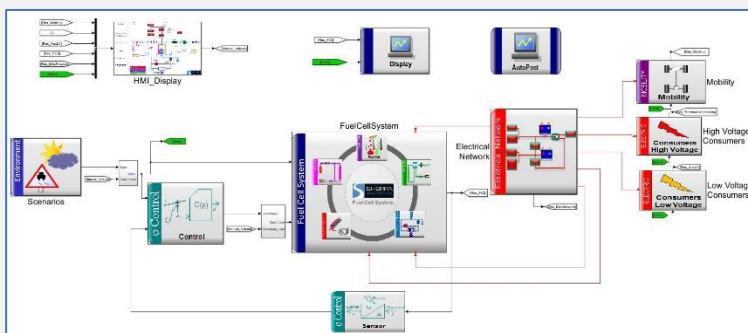

Simulink Model of the Fuel Cell Platform

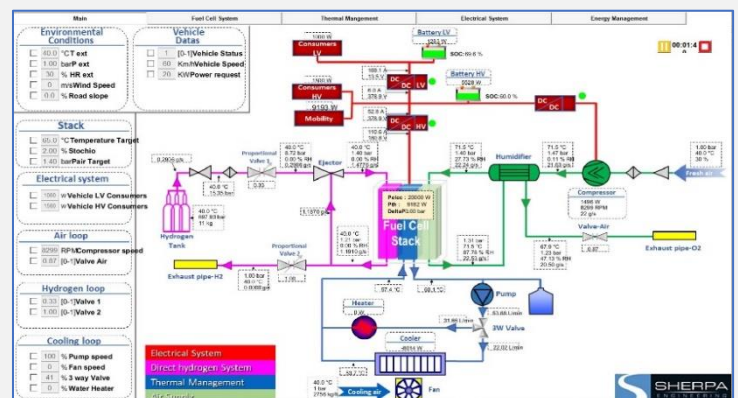

HMI Main Window – Real time visualization

Sherpa Engineering has developed a simulation platform that covers the entire Fuel Cell system including its control logics and its electrical and powertrain environment. The following subsystems are included:

- **Air subsystem:** supply of the air at the required pressure, flow rate, temperature, and humidity
- **Hydrogen subsystem:** supply of hydrogen at the required pressure and flow rate
- **Cooling subsystem:** guarantee cooling of Fuel Cell stacks and ensure small temperature gradient across stacks
- **Electrical subsystem:** manage the storage and consumption of electrical energy in the various vehicle subsystems.
- **Powertrain subsystem:** represents the electric mobility powertrain
- **Control subsystem:** includes basic control laws, diagnosis, monitoring and the system supervisor

## Easy to customize / Combining multi-physics modeling and control design

You can adapt plant model architecture to your own needs. Load your own control software and connect it to plant multi-physics model directly in the platform. Sherpa is able to help you in these kinds of tasks. We can also deliver to you completely custom-made platforms.

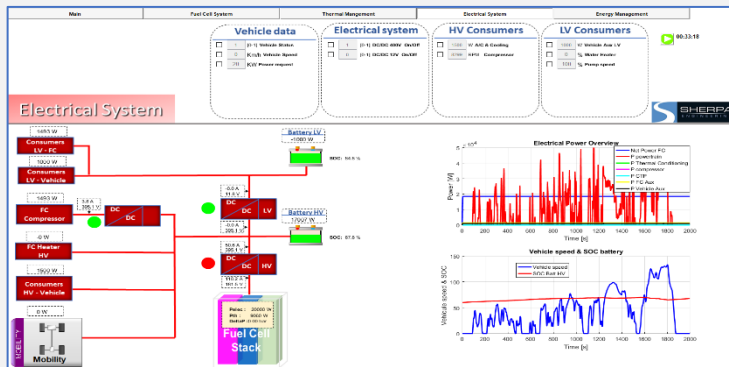

HMI Electrical System Window

**Electrical Network** allows you to link your Fuel Cell system to different consumers as Low/High Voltage and your Powertrain system.

## System Design

We are strongly involved in system design and in the choice of actuators (air compressor, radiator, valves, etc). We ensure the best choice of components using a dynamic environmental model of the system (thanks to Bond-Graph methodology). This model, based on Thermofluid equations, considers characteristics of each component and helps to validate requirements of your system.

## Detection of hydrogen leaks

A common safety issue in Fuel Cell systems is hydrogen leaks, which may cause very dangerous faults. In addition to hydrogen sensors, we have developed a method for leaks detection in Fuel Cell systems. This procedure includes an hydrogen storage tank, a primary shut-off valve and a secondary shut-off valve in the supply line.

## Diagnosis

The target of diagnosis system is to avoid any deterioration of Fuel Cell stack and to increase its lifespan. Sherpa Engineering proposes a simple and efficient diagnosis-oriented model. It includes the following three main monitoring modules:

- Cell voltage monitoring
- Vital parameters for a safe and proper operation: Membrane temperature, air flow rate, stoichiometric ratio, hydrogen and air pressure stack inlet, pressure differential, etc.
- Actuators and sensors diagnosis

Fault detection and identification procedure are based on a reduced model of the Fuel Cell. Residuals (difference between observation and predicted value) are calculated and used to decide on the occurrence of any fault, its type and its location.

You can easily couple your **Thermal Management system** to your Fuel Cell system and insure the cooling capacity of whole system.

**Energy Management Window** allows you to size your components and verify the distance covered under different driving scenarios.

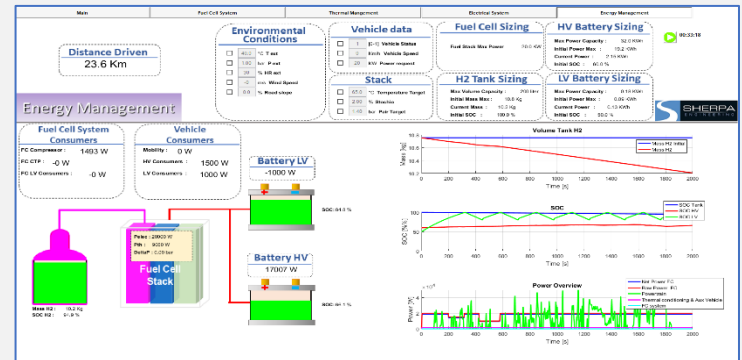

HMI Energy Management Window

## Validation process

- Fast Prototyping with Simulink and dSPACE systems
- Hierarchical decomposition: using partial bench to validate subsystems before final validation on the entire Fuel Cell system
- Model based design: by running the same tests on model, we anticipate its performance in lab or in real system
- **HIL compliance**: our models are developed in fixed step and are compliant with Real Time devices



Bench validation