

The classical level control of the bottom of a distillation column is usually performed by a simple PID controller acting on the bottom flow rate. In the present case, that bottom flow rate is the feed rate for the down-stream unit and it is not available for the control of the considered level.

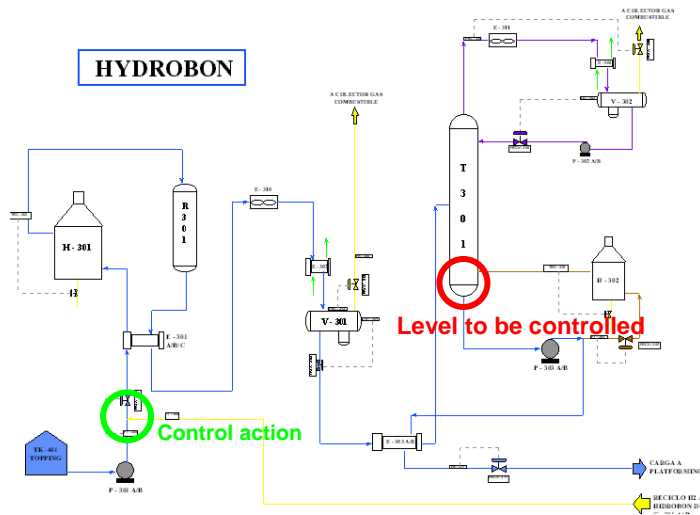

This situation leads to the necessity of using another degree of freedom for the level control: the selected manipulated variable (control action) is the feed rate of the column to handle its own bottom level.

At this point, the main difficulty comes from the integrative effect on one hand and from the quite large time delay. These two aspects are such that the regular PID does not give acceptable performances.

The PCR controller has also to take into account the bottom flow rate getting out of the column and feeding the reformer unit down-stream. This bottom flow rate is a strong disturbance for the level control, with a much shorter delay.

The PCR control modules were selected as a good solution for solving the problem. The controller model has been identified from collected plant tests, using the PCR control design tool on a PC.

An interest of PCR Model Based Predictive Control is the fact that the control parameters are not tuning parameters (as the factors P, I and D in the regular PID controller), but specified closed loop behaviour: the closed loop time response.

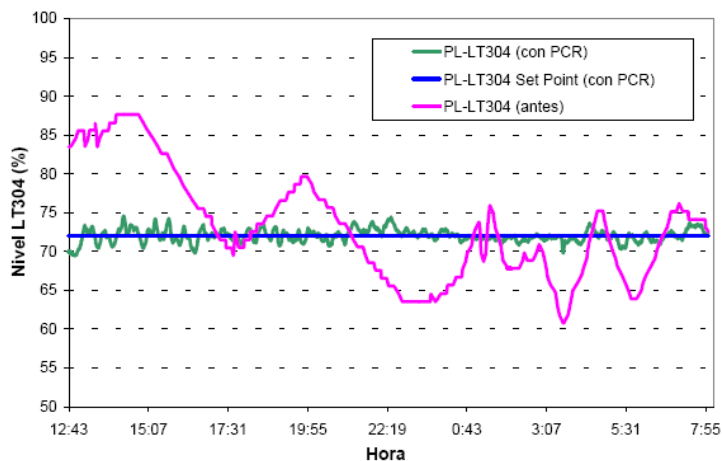

The control architecture is a cascade of 2 controllers: the PCR controller predicts the behaviour of the level and computes the necessary feed rate in order to satisfy the specified target on the level.

And the computed action is the flow rate set point which is sent to a FRC (classical PID) acting on the valve position.

The target specified on the level is given in terms of range: it is useless to control tightly the level whose specification is only to be kept within a given range.

A PCR module is dedicated to the computation of the closed loop time response specified to the PCR controller from bounds defined by the user: the control is smooth when the measured value is close to its set point and stronger when it gets out of the defined zone. This procedure is highly appreciated by the users because the applied actions are much smoother when the level is inside the acceptable range.