

Better dynamic control of the temperature in an exothermic chemical reactor allows increasing the injection of reactants.

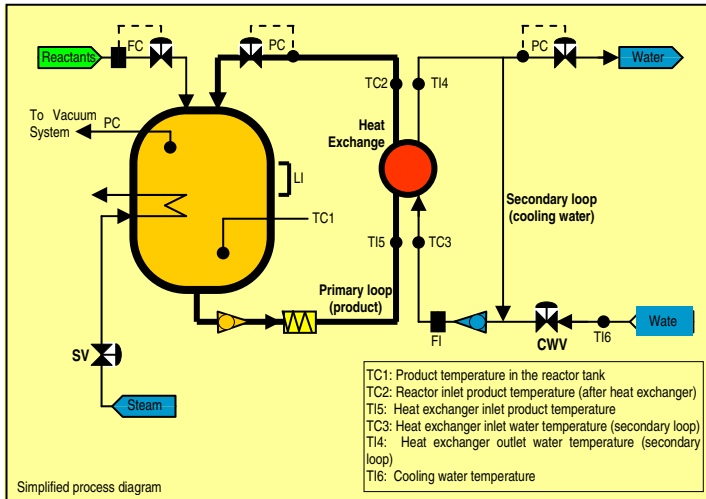

A polyols reactor required a significant improvement of the stability.

The exothermic reaction requires an efficient cooling in order to respect a temperature set point with the following trade-off: the highest possible value because that increases the strength of reaction and therefore speeds up the production while respecting a high constraint.

The methodology relies on a dynamic model of the process to be controlled. It allows the prediction of the behaviour of the temperatures and the computation of the actions to be applied to the unit.

The PCR control modules are used with profit on this reactor, as the performances of traditional PID controllers were not good enough.

The fluctuations are reduced at least by a ratio 2 and that makes possible for the producer to increase the temperature set point closer to the high constraint.

This improvement has an effect on several aspects: fewer movements of the valves (longer process availability), no more competitive actions between heating and cooling (energy saving).

Total batch duration is reduced due to the increase of the injection flow rate of reactants.

Such increase is now possible because the temperature deviations have been reduced.

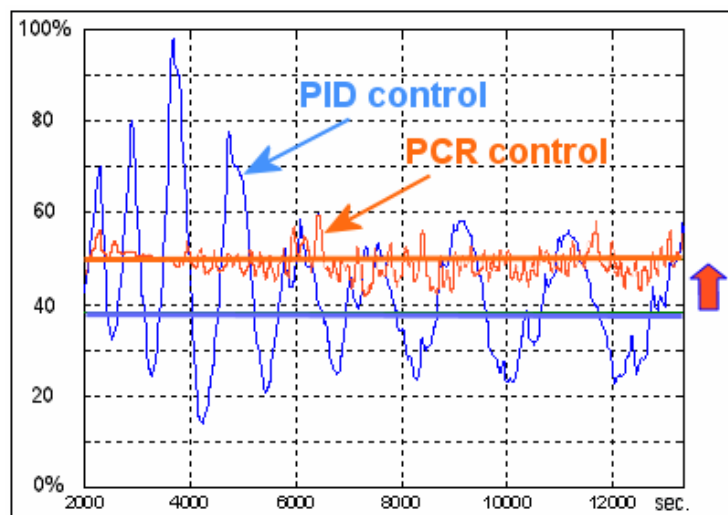

Improvement of the temperature control

The increase of production, coming from the shift upwards of the temperature set point, is estimated between 17 and 20%.

Another advantage is the capability to perform reproducible operating conditions for the different batches, and therefore to obtain a more uniform quality of the product.



SHERPA ENGINEERING
269-287 rue de la Garenne
F - 92000 Nanterre
Tel : 33 1 47 82 08 23
Fax : 33 1 47 82 00 96

MODELLING and CONTROL DESIGN

Email : info@sherpa-eng.com
Web : www.sherpa-eng.com



Design and provision of studies in the field of system engineering

ISO 9001
VERSION 2000

QUAL/2002/19292