

Several process variables were to be improved on this power plant: steam temperature control, tank level control and turbine inlet pressures control (collector). All these control loops are performed by PCR controllers embedded into Schneider Electric MOMENTUM PLCs.

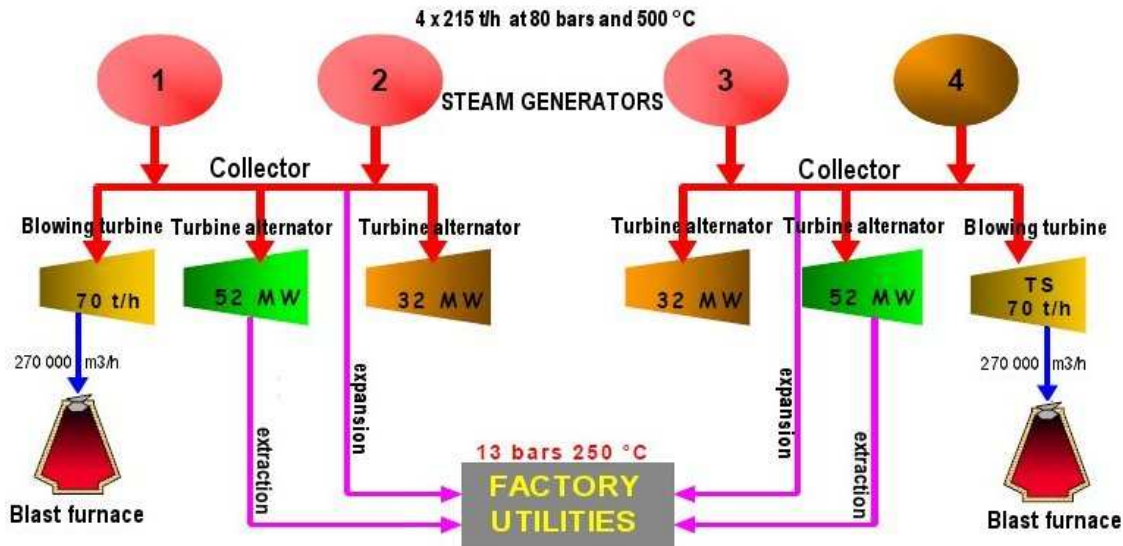

The steam generators are fed by different kinds of fuels. When switching from a combination of blast furnace gases to a mix of oil and other fuels, the temperature of the steam is much disturbed. If the high limit of the steam temperature is not respected, the steam generator is shut-down for security reasons.

The control of that temperature is performed by a cascade of two PCR controllers, acting on the flow rate set point of injected water. This set point is sent to a FRC (regular PID controller).

The second aspect of the PCR application is the level control of the steam generators which had to be kept within a $\pm 10\%$ range in spite of quite fast changes of the load. This control acts on the feed rate of the 'feed water'.

The last application concerned the control of the turbine inlet pressures at the place called collector. The way PCR controls that pressure is by acting on the set point of the flow rate of the fuels through a cascade.

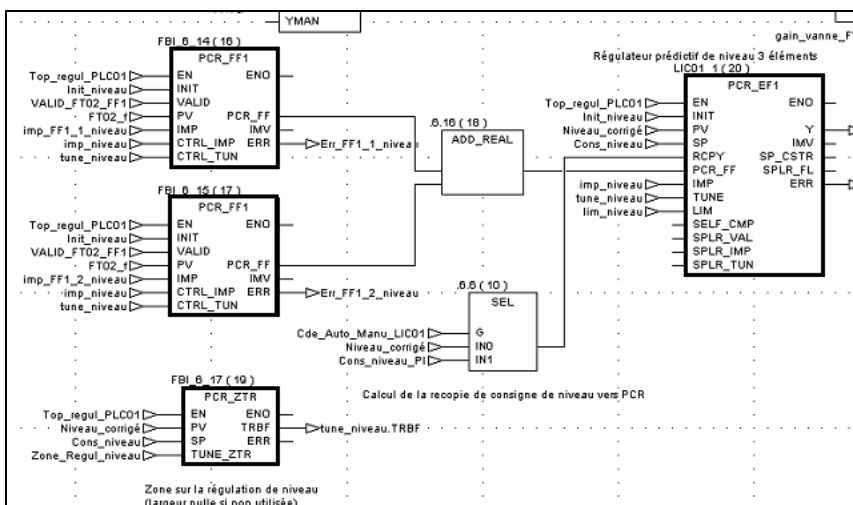

The whole control structure was designed on a simulated process built in the MATLAB/SIMULINK environment.

This structure is then copied into the CONCEPT environment (see the corresponding diagram)

Once designed, the control structure and the parameters of the controllers were transferred into the PLC.

